

VERTICAL AIR RECEIVERS

With Topplate

Less Topplate

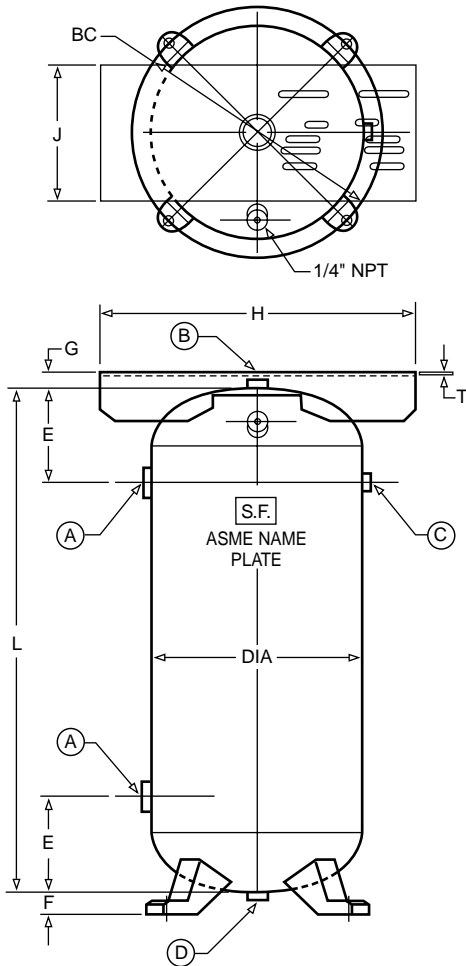

DESIGN A

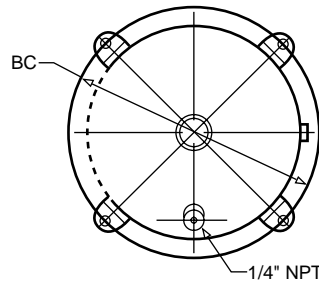

DESIGN B

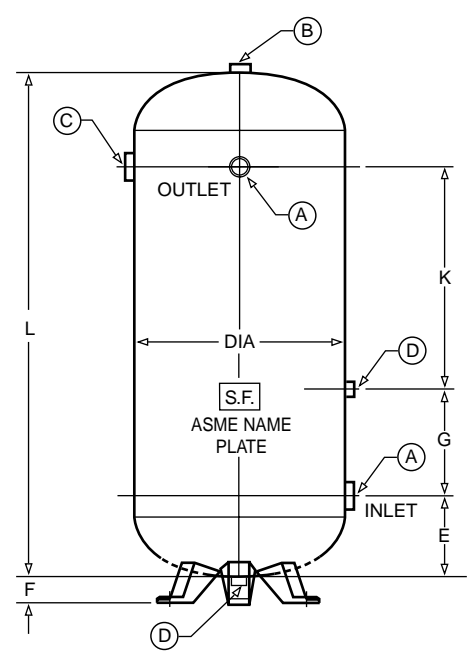
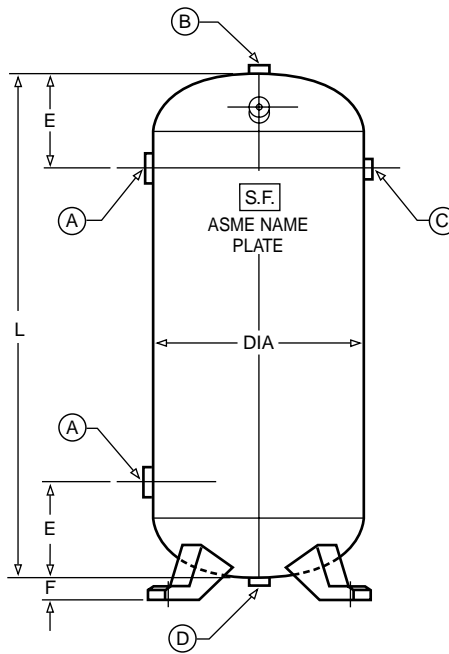
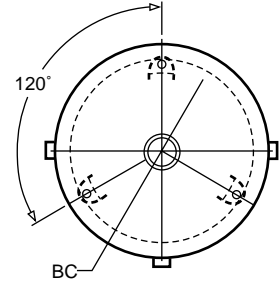

WITH TOPPLATE

P/N	GAL	DIA	L	PSI	OPENINGS (NPT) "				DIMENSIONS "							
					A	B	C	D	E	F	G	H	J	K	T	BC
A10041	30	16	38	200	1-1/2	1/2	1/4	1/4	8	1-3/4	1-1/2	23	9	-	3/16	18-3/4
A10044	60	20	48	200	2	3/4	1/4	1/4	9	2-1/4	1-1/2	30	13	-	3/16	23-3/4
A10046	80	24	46	200	2	1	1/4	1/2	11	3-3/8	1-1/2	30	13	-	3/16	25-1/2
A10047*	120	30	46	200	2	1	1/4	1/2	12	6	3-7/8	39	15	-	1/4	26

DESIGN A - LESS TOPPLATE

A10040	30	16	38	200	1-1/2	1/2	1/4	1/4	8	1-3/4	-	-	-	-	-	18-3/4
A10043	60	20	48	200	2	3/4	1/4	1/4	9	2-1/4	-	-	-	-	-	23-3/4
A10045	80	24	46	200	2	3/4	1/4	1/2	11	3-3/8	-	-	-	-	-	25-1/2

DESIGN B - LESS TOPPLATE

A11175	80	20	63	200	2	1	1/2	1/2	10	2-1/4	21	-	-	22	-	23-3/4
A11176	120	24	69	200	2	1	1/2	1/2	12	3-3/8	26	-	-	18	-	25-1/2
A11177	200	30	72	200	2	1	1/2	1/2	12	3-3/8	15	-	-	32	-	25-1/2
A11178	240	30	84	200	2	1	1/2	1/2	12	3-3/8	19	-	-	40	-	25-1/2

* Skirt instead of pressed steel feet