

Heat Reactivated Air Dryers



Externally Heated & Blower Purge

Heat Reactivated Desiccant Air Dryers

Airtek heat reactivated desiccant air dryers use the adsorption method to remove moisture from compressed air. Pressure dew points ranging from minus 40°F (-40°C) to minus 100°F (-73°C) are achieved by directing the flow of saturated compressed air over a bed of desiccant. The most commonly used desiccant is activated alumina, a spherically shaped, hygroscopic material, selected for its consistent size, shape and extreme surface to mass ratio. This physically tough and chemically inert material is contained in two pressure vessels commonly referred to as "dual" or "twin towers". As the saturated compressed air flows through the bed of the "on line" tower, its moisture content adheres to the surface of the desiccant. The dry compressed air is then discharged from the vessel into the distribution system.

A master controller cycles the flow of compressed air between the towers. While one tower is "on line" drying, the other tower is "off line" regenerating. Regeneration, sometimes referred to as "purging", is the process of stripping the accumulated moisture from the "off line" bed.

Both types of Airtek heat reactivated dryers combine heat with either a small portion of the dried compressed air or with forced ambient air to affect regeneration.

As heated, low pressure, purge air flows gently through the regenerating bed, it desorbs the moisture that had accumulated on the surface of the desiccant during the drying cycle and exhausts it to the atmosphere.



TWP770

Flow Schematic

Airtek's patented Multi-Port Regeneration System (TWP Series) affects superior desiccant bed regeneration and, as a result, provides better and more consistent performance. The Multi-Port Regeneration System injects heated purge air at precise points up and down the towers length providing a more balanced distribution of heat. This system prevents the desiccant on top from prematurely deteriorating while providing the bottom of the chamber with enough heated purge air to allow complete regeneration on every cycle.

The energy saving temperature monitoring system senses the exiting purge air temperature. When the purge air temperature increases to a pre-set point at which the desiccant bed is fully heated and regenerated, the blower and heater are turned off.

Airtek's Secondary Blowdown System is standard on all TWP Series and TWB Series heat reactivated air dryers 1000 SCFM and larger. It improves performance and efficiency while increasing desiccant life. The depressurization stage strips moisture from the bottom of the tank through a purge muffler. Once depressurization is complete, the system switches to the main exhaust where final regeneration is accomplished with low pressure purge air. Bypassing the exhaust mufflers eliminates back pressure and allows for more thorough regeneration.

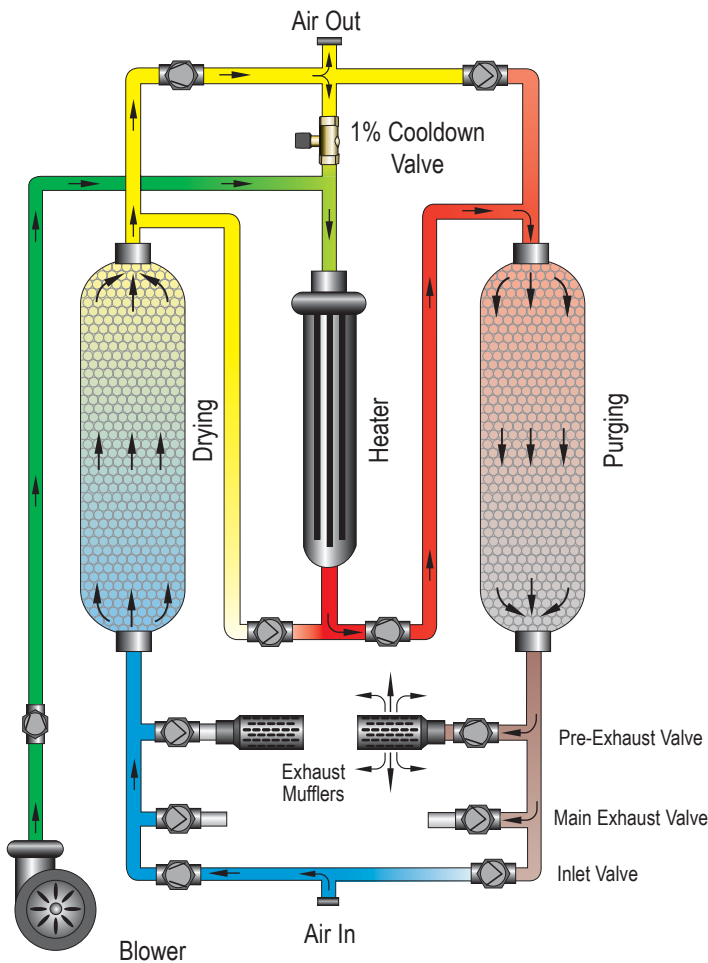

Airtek Blower Purge (TWB)

Airtek Externally Heated with Multi-Port (TWP)

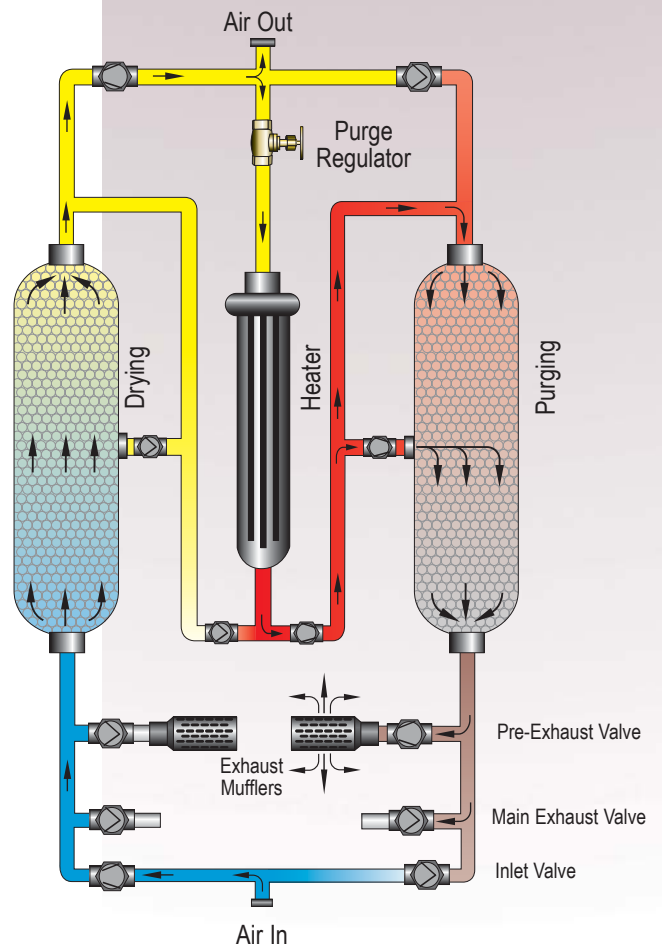

Control Center

The Control Center is a full-featured instrumentation package which results in superior functionality. The panel monitors, analyzes and collects all critical pressures, temperatures and operating conditions. The information is continuously collected and can be viewed on the message center screen. Information collected for the latest 24 hr. period can be downloaded for evaluation. Abnormal conditions are immediately alarmed and displayed on the message center.

Included with every Control Center is a communications port making *StarWatch™ Services* accessible. With *StarWatch™* activated Airtek can monitor and analyze every moment of operation, 24-7; it can be done wirelessly. When *StarWatch™* is active on an installation, it is as if an Airtek factory employee is right in your plant, advising your process engineer.

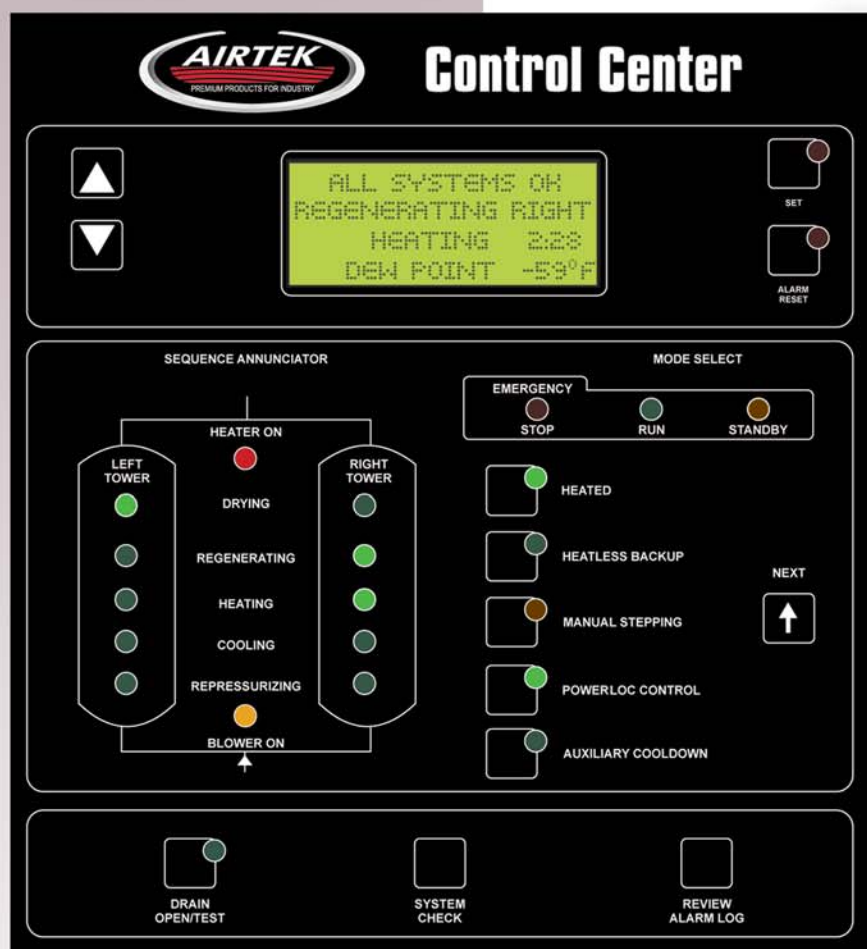

RemoteWatch™ software is standard with the Control Center. This allows you to monitor every detail of operation, including all alarms from any PC.

Control Center Standard Features

- StarWatch™ (remote analysis system) ready w/68 channels of data & over 55 process values.
- RemoteWatch™ software (user monitor & control) from any PC. Includes virtual control panel, diagrams, and graphics.
- Total system temperature and pressure instrumentation package.
- 4-20mA input with set-point and alarm for connection to your flow meter.
- Intelligent display with operational information.
- Full system retentive alarm network (event) log.
- Programmable process set-points.
- Dryer operating "state" annunciation display.
- Automatic data logging 24-7-365 of all operational information, both analog & digital.
- 16 channel "programmable" common alarm.
- RS-232 communications port.
- StarWatch™ connectivity telco line.
- Common alarm relay allows user selectable alarm output to connect to you process

Quick Glance Operational Status

Sequence Annunciator

Shows which tower is drying and whether the off-line tower is heating, cooling or repressurizing.

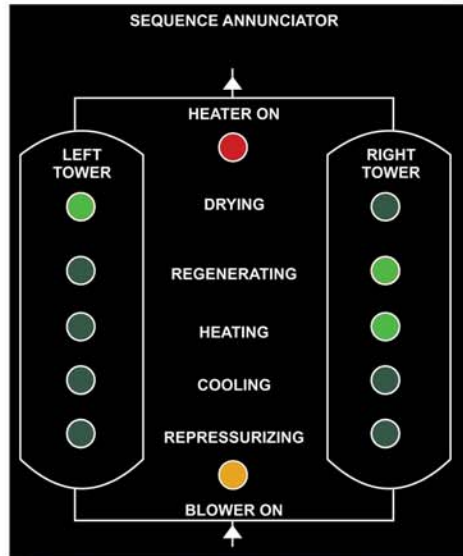

Manual Test Mode

Allows the operator to quickly and safely step the dryer through a complete 8 hour cycle.

ThermaLoc

The Control Center also controls Airtex's "ThermaLoc" heater protection system. ThermaLoc ensures maximum reliability and eliminates the safety concerns often associated with heat reactivated dryers. Heaters are protected by a totally redundant dual shutdown system that utilizes independent mercury contactors. In addition to the redundant temperature controllers, the system monitors pressure and shuts the heater down in the event of low line pressure. Blower purge dryers have controls to prevent the heater from energizing if the blower is not running.

Dual Mode Heatless Back Up System

Allows the dryer to function in either the primary heated mode or the auxiliary heatless mode. Should the system experience a temporary overload or a heater failure, the dryer can easily be switched over to operate in the heatless mode. This way the dryer will remain on line until such time as service can be conveniently scheduled. The Dual Mode Back Up System offers unparalleled flexibility, eliminates downtime and prevents business interruptions.

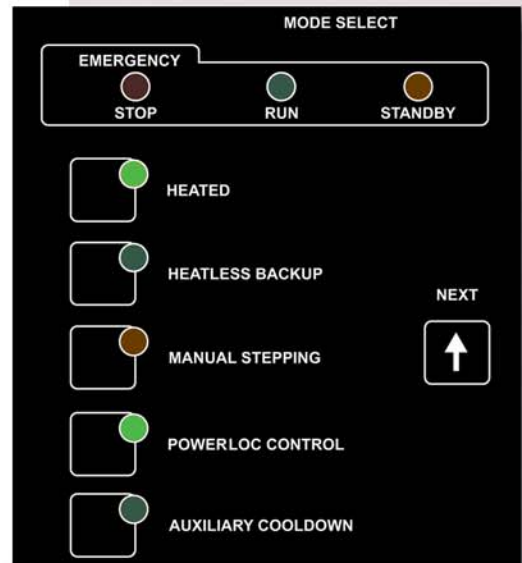

Switching Valves

Non-Lubricated Valves

Dryers up to 800 SCFM are equipped with our time-proven and dependable non-lubricated switching valves. These independent, air operated valves are specifically designed for compressed air service. They are resistant to desiccant dust and can be maintained without being removed from the dryer.

Rotary Actuated Valves

High performance, Rotary Actuated Switching Valves are standard on dryers 1000 SCFM and larger. These premium, air operated butterfly valves are specifically designed for compressed air. They provide more opening and closing force compared to other types of valves. An indicator shows the "opened/closed" position of the valve and service can be performed without disturbing dryer piping.

These valves are so reliable, they carry a Three Year Factory Warranty.



Tower Insulation

The tower, heater, and purge lines are insulated to increase dryer performance and efficiency by reducing radiant heat loss. It also keeps the unit within the safety parameters set forth by OSHA. Insulation suitable for indoor service is standard on all Airtek Heat Reactivated Dryers (Insulation suitable for outdoor service is an available option).

Design Parameters

Airtek Externally Heated and Blower Purge dryers are designed to process a specific volume of compressed air and deliver it to the discharge at a desired pressure dew point. Both dryers are rated for a -40°F (-40°C) pressure dew point. Dew point spikes, inherent on all blower purge dryers, can be reduced by activating Airtek's standard Supplemental 1% Cooldown Purge feature. Standard ratings are based on inlet conditions of $+100^{\circ}\text{F}$ (38°C), 100 PSIG (2.7 Bar) and 100% flow. (Dryer performance will vary with different inlet conditions).

Moisture load, velocity, contact time and cycle time determine the amount of desiccant required. To assure design performance, each tower is carefully sized to allow a minimum contact time of 7 seconds. To prevent bed movement, desiccant dusting and fluidization, air flow velocity is kept below 55 feet per minute. Externally Heated and Blower Purge dryers are designed for an eight-hour cycle (four hours "on-line" drying, four hours "off-line" regenerating, cooling and repressurizing). For significant energy savings and Digital Dew Point Readout, all Airtek desiccant dryers can be equipped with an optional PowerLoc Demand Control Module.

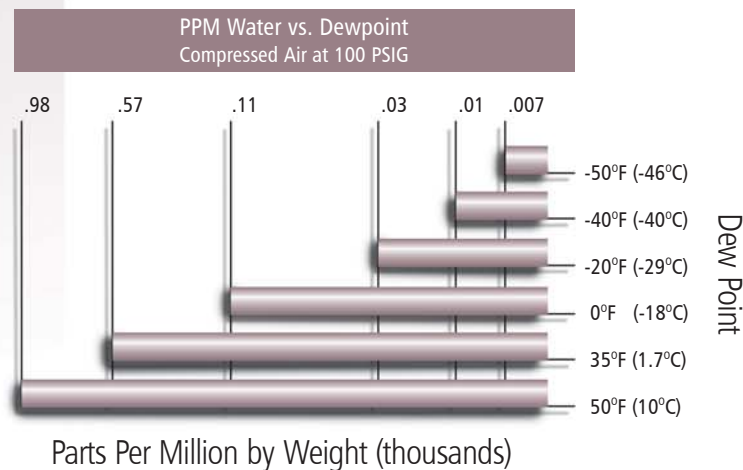

Complete Air Treatment System

Without proper filtration, desiccant air dryers will not work. Desiccant dryers are designed to adsorb vapor from compressed air; they are not designed for liquid. When liquid, especially oil, is allowed to enter the desiccant chamber, it coats the desiccant material preventing any further adsorption. Oil coated desiccant can not be regenerated, and must be replaced. To protect the desiccant from contact with liquids, a coalescing pre-filter is required. The pre-filter must be properly sized and properly installed with a dependable automatic drain and a visual indicator to determine element condition. To protect downstream equipment from potential damage caused by the abrasive effects of desiccant dust, a particulate after-filter is also required.

Most field problems experienced with desiccant air dryers are the result of improper filter selection, installation, maintenance, and/or draining of condensate.

Considering the importance of filtration to dryer performance, Airtek recommends that all desiccant dryers be ordered as a complete, factory assembled Air Treatment System. The Optional Airtek Package "E" includes: properly sized, factory installed coalescing prefilter and particulate after filter with electronic drain system (No Loss Demand Drains standard on 400 SCFM and larger), and integrated digital element condition indicators.

Factory packaging, with matched components and single point connections reduces installation costs, ensures performance and allows Airtek to assume total responsibility for system integrity.



TWB5000

Package Schematic

Package "E"



Includes dryer with factory installed pre-filter and after-filter.

Package "EB"

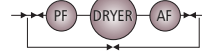

Includes dryer with factory installed pre-filter and after-filter with system bypass.

Package "EC"

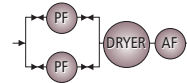

Includes dryer with factory installed dual selectable pre-filters and single after-filter.

Package "ED"

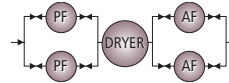

Includes dryer with factory installed dual selectable pre and after-filters.

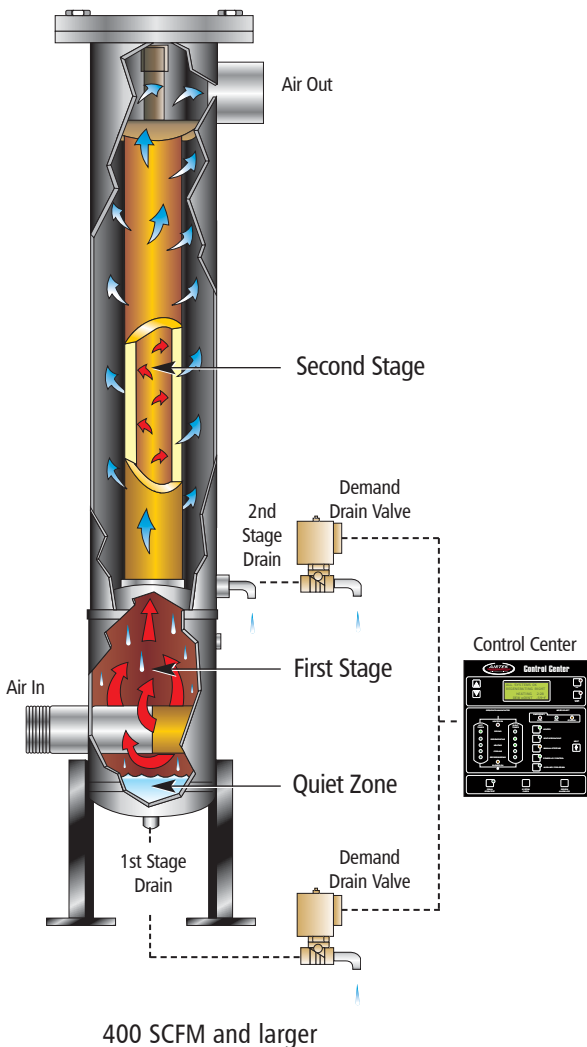

Filters

Airtek Package "E" systems match our TWP and TWB dryers with Airtek high performance filters. In-line filters (JW) are used on systems 100 through 300 SCFM and two stage (JL) severe duty filters are used on systems 400 SCFM and larger. Mist eliminators are available as extra protection.

The coalescing pre-filter is installed at the dryer inlet. It protects the dryer by removing liquids and reducing the contamination level of the compressed air to .01 PPM by weight. The element is DOP rated at 99.9+% efficient in the 0.3 to 0.6 micron range. An integrated digital indicator is provided to determine element condition. An electronic drain valve is provided on systems 100 through 300 SCFM to ensure proper drainage. On systems 400 SCFM and larger a zero air loss demand drain is provided. The drain controller includes push to test, drain alarm, and common alarm contact.

To protect downstream equipment from desiccant dust a particulate after-filter is installed at the dryer discharge. The after-filter element is designed to remove solid particulates from compressed air. The hybrid pleated filter media provides high dirt retention, low pressure drop, and long element life. The element is 99+% effective in removing particles 0.9 micron and larger. A integrated digital element condition indicator is also provided.

Note: Optional Mist Eliminators are available as extra protection for standard packages.

PowerLoc Energy Management System

The Control Center is designed to accommodate Airtek's optional PowerLoc Demand Controller.

PowerLoc automatically adjusts energy use to actual moisture load. Moisture loading is affected by inlet temperature, pressure, relative humidity and flow. These conditions vary throughout the day and rarely combine in such a manner as to produce maximum moisture loads. An inlet temperature reduction of just 20°F (-7°C) will reduce the moisture load by almost 50%. Desiccant dryers are normally sized for "worst case" operation with the cycle fixed to accommodate maximum moisture loads. Because the fixed cycle does not compensate for fluctuating loads, dryers not equipped with PowerLoc waste energy by regenerating more often than necessary. PowerLoc eliminates this unnecessary use of energy by delaying regeneration until the total design moisture load is achieved. The system monitors actual moisture loading and limits the number of purge cycles accordingly.

At \$0.08 per KWH, the PowerLoc would save \$6,730 annually when used with a 1000 SCFM externally heated dryer operating at 75% load for 8,000 hours, at an average inlet temperature of +80°F (27°C). Digital dew point control provides for additional energy savings by allowing the operator to select higher dew points when appropriate. The moisture probe is contained in and protected by a rugged, stainless steel housing that also contains an electronics package for continuous self calibration, temperature compensation, and signal stabilization. Due to less frequent cycling, switching valves and desiccant will last longer and require less maintenance.

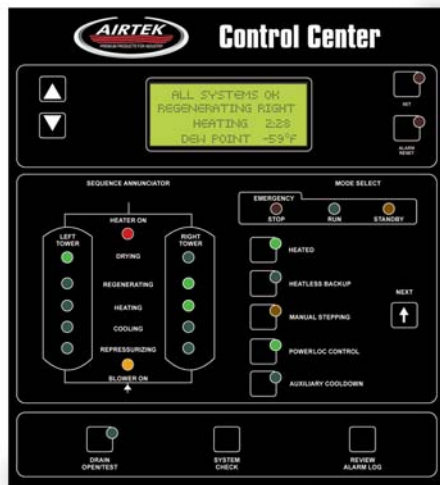
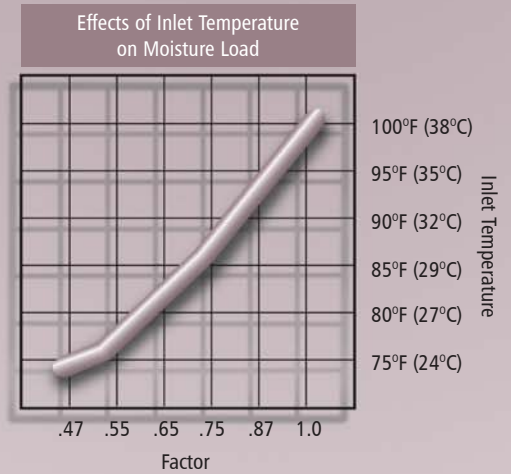

The PowerLoc ceramic sensor is made from state-of-the-art metalized ceramic and replaces traditional materials such as aluminum, silicon and hygroscopic salts. This fast response sensor is made from a ceramic tile that is plated and vapor deposited to form a surface that is very sensitive to small changes in water vapor pressure.

The proprietary coating processes make the ceramic sensor inherently faster to respond than other impedance or capacity sensors currently available. The ceramic sensor features the latest digital technology with calibration data stored directly in the sensor's memory, and is equipped with a built-in thermistor for automatic temperature compensation. The PowerLoc is traceable to the National Institute of Standards and Technology. A certificate of traceability is available.

The PowerLoc ceramic sensor is protected by an 80 micron sintered metal guard and is enclosed in a rugged, stainless steel housing with a pressure rating of 5000 PSIG. This housing increases the sensor's ability to withstand reasonable shock and vibration.



Engineering Data Specifications

TWP Externally Heated Desiccant Air Dryer

MODEL	Capacity SCFM @ 100 PSIG (Nm ³ /min@6.9 Bar)	Approximate Purge SCFM (Nm ³ /min)	Heater KW	Average KW	Recommended Package "E"	Dryer with Package "E"				Air In/Out (mm)	Power Supply Volts/Phase/Hz
						Length (mm)	Width (mm)	Height (mm)	Weight Lbs (Kg)		
TWP100	100 (2.8)	7 (.2)	1.5	.74	TA-PE 0111	37 (940)	33 (838)	82 (2083)	680 (308)	1" (25.4)	120 / 1 / 60
TWP130	135 (3.8)	9.5 (.27)	1.5	1.0	TA-PE 0151	37 (940)	33 (838)	82 (2083)	720 (327)	1" (25.4)	120 / 1 / 60
TWP200	200 (5.7)	14 (.4)	3	1.5	TA-PE 0201	44 (1118)	39 (991)	82 (2083)	920 (417)	1-1/2" (38.1)	240 / 1 / 60
TWP250	250 (7.1)	17.5 (.5)	3	1.9	TA-PE 0301	45 (1143)	39 (991)	84 (2134)	1180 (535)	1-1/2" (38.1)	240 / 1 / 60
TWP300	300 (8.5)	21 (.6)	4	2.3	TA-PE 0301	47 (1194)	39 (991)	84 (2134)	1370 (621)	1-1/2" (38.1)	480 / 3 / 60
TWP400	400 (11.3)	28 (.8)	6	3.0	TA-PE 0401	74 (1880)	41 (1041)	90 (2286)	1400 (635)	2" (50.8)	480 / 3 / 60
TWP500	500 (14.1)	35 (1.0)	6	3.7	TA-PE 0601	74 (1880)	41 (1041)	90 (2286)	2060 (934)	2" (50.8)	480 / 3 / 60
TWP600	600 (17.0)	42 (1.2)	9	4.5	TA-PE 0601	74 (1880)	41 (1041)	96 (2438)	2350 (1066)	2" (50.8)	480 / 3 / 60
TWP770	800 (22.7)	54 (1.5)	9	6.0	TA-PE 0901	96 (2438)	48 (1219)	90 (2286)	3035 (1377)	2" (50.8)	480 / 3 / 60
TWP1000	1000 (28.3)	70 (2.0)	13	7.4	TA-PE 1001	96 (2438)	48 (1219)	101 (2564)	4195 (1903)	3" (76.2)	480 / 3 / 60
TWP1200	1250 (35.4)	84 (2.4)	13	8.9	TA-PE 1251	96 (2438)	48 (1219)	101 (2564)	5215 (2365)	3" (76.2)	480 / 3 / 60
TWP1500	1500 (42.5)	105 (3.0)	18	11.2	TA-PE 1601	144 (3658)	72 (1829)	101 (2564)	5715 (2592)	4" (101.6)	480 / 3 / 60
TWP2000	2200 (62.3)	140 (4.0)	25	16.4	TA-PE 2001	144 (3658)	72 (1829)	101 (2564)	6250 (2835)	4" FL (101.6)	480 / 3 / 60
TWP2600	2600 (73.6)	182 (5.1)	25	19.3	TA-PE 2601	144 (3658)	72 (1829)	101 (2564)	6750 (3062)	4" FL (101.6)	480 / 3 / 60
TWP3000	3000 (84.9)	210 (5.9)	30	22.3	TA-PE 3001	144 (3658)	72 (1829)	110 (2794)	7055 (3200)	6" FL (152.4)	480 / 3 / 60
TWP4000	4000 (113.3)	280 (7.9)	38	29.7	TA-PE 4001	168 (4267)	78 (1981)	114 (2896)	18080 (8201)	6" FL (152.4)	480 / 3 / 60
TWP5000	5000 (141.6)	350 (9.9)	50	37.0	TA-PE 5001	210 (5334)	90 (2286)	114 (2896)	20710 (9394)	6" FL (152.4)	480 / 3 / 60
TWP6000	6000 (169.9)	420 (11.9)	60	44.6	TA-PE 6001	210 (5334)	90 (2286)	114 (2896)	25200 (11431)	6" FL (152.4)	480 / 3 / 60
TWP7500	7500 (212.4)	525 (14.9)	85	56.0	TA-PE 7501	210 (5334)	90 (2286)	114 (2896)	27100 (12292)	8" FL (203.2)	480 / 3 / 60
TWP9000	9000 (254.8)	630 (17.9)	100	69.7	TA-PE 9001	210 (5334)	96 (2438)	114 (2896)	28600 (12973)	8" FL (203.2)	480 / 3 / 60

TWB Blower Purge Desiccant Air Dryer

MODEL	Capacity SCFM @ 100 PSIG (Nm ³ /min@6.9 Bar)	Blower HP	Heater KW	Average KW	Recommended Package "E"	Dryer with Package "E"				Air In/Out (mm)	Power Supply Volts/Phase/Hz
						Length (mm)	Width (mm)	Height (mm)	Weight Lbs (Kg)		
TWB100	100 (2.8)	.75	3	1.8	TA-PE 0112	54 (1372)	42 (1067)	78 (1981)	1050 (476)	1" (25.4)	120 / 1 / 60
TWB200	200 (5.7)	.75	6	2.9	TA-PE 0202	54 (1372)	42 (1067)	78 (1981)	1500 (680)	1-1/2" (38.1)	480 / 3 / 60
TWB300	300 (8.5)	1.5	6	4.7	TA-PE 0302	66 (1676)	48 (1219)	86 (2184)	1900 (862)	1-1/2" (38.1)	480 / 3 / 60
TWB400	400 (11.3)	1.5	9	5.9	TA-PE 0402	74 (1880)	41 (1041)	90 (2286)	2180 (989)	2" (50.8)	480 / 3 / 60
TWB500	500 (14.1)	2	12	7.4	TA-PE 0602	74 (1880)	41 (1041)	90 (2286)	2840 (1288)	2" (50.8)	480 / 3 / 60
TWB600	600 (17.0)	2	12	8.6	TA-PE 0602	96 (2438)	48 (1219)	96 (2438)	3420 (1551)	2" (50.8)	480 / 3 / 60
TWB770	800 (22.7)	5	18	13.4	TA-PE 0802	108 (2743)	54 (1372)	90 (2286)	4490 (2037)	2" (50.8)	480 / 3 / 60
TWB1000	1000 (28.3)	5	18	15.7	TA-PE 1002	108 (2743)	54 (1372)	101 (2565)	5700 (2585)	3" (76.2)	480 / 3 / 60
TWB1200	1250 (35.4)	5.5	25	18.4	TA-PE 1252	108 (2743)	54 (1372)	113 (2870)	6300 (2858)	3" (76.2)	480 / 3 / 60
TWB1500	1500 (42.5)	7.5	30	23.5	TA-PE 1602	144 (3658)	72 (1829)	100 (2540)	8250 (3742)	4" (101.6)	480 / 3 / 60
TWB2000	2200 (62.3)	7.5	38	31.6	TA-PE 2002	144 (3658)	72 (1829)	100 (2540)	9850 (4468)	4" (101.6)	480 / 3 / 60
TWB2600	2600 (73.6)	10	50	38.3	TA-PE 2602	156 (3962)	84 (2134)	110 (2794)	12210 (5538)	4" (101.6)	480 / 3 / 60
TWB3000	3000 (84.9)	10	60	42.9	TA-PE 3002	156 (3962)	84 (2134)	111 (2819)	15170 (6881)	6" FL (152.4)	480 / 3 / 60
TWB4000	4000 (113.3)	15	75	58.6	TA-PE 4002	204 (5182)	96 (2438)	114 (2896)	18910 (8577)	6" FL (152.4)	480 / 3 / 60
TWB5000	5000 (141.6)	15	100	70.2	TA-PE 5002	204 (5182)	96 (2438)	114 (2896)	21590 (9793)	6" FL (152.4)	480 / 3 / 60
TWB6000	6000 (169.9)	20	115	86.0	TA-PE 6002	204 (5182)	96 (2438)	114 (2896)	26500 (12020)	6" FL (152.4)	480 / 3 / 60
TWB7500	7500 (212.4)	25	135	107.0	TA-PE 7502	210 (5334)	96 (2438)	114 (2896)	28800 (13063)	8" FL (203.2)	480 / 3 / 60
TWB9000	9000 (254.8)	30	150	129.0	TA-PE 9002	220 (5588)	102 (2591)	126 (3200)	32100 (14560)	8" FL (203.2)	480 / 3 / 60

- Notes:
- Dimensions and weight are for dryer with Package E installed.
 - Dimensions measured in inches and millimeters.
 - Weight measured in pounds and kilograms and includes desiccant (shipped loose models 1500 and up).
 - Specifications and dimensions are subject to change without notice.

Available Equipment

Standard Equipment

- Full Instrumentation
- 5-Year Heater Warranty
- 3-Year Valve Warranty (1000 SCFM and Larger)
- Dual Mode, Heatless Backup
- Failure to Switch Alarm
- Systems Sequence Annunciator
- Cycle Stepping
- Standby Mode
- Independent Switching Valves
- High Performance Butterfly Valves (1000 SCFM and Larger)
- Indoor Tower Insulation
- Long Life, Low Watt Density Heaters
- Dual Mercury Contactors (ThermaLoc)
- Heater Thermostats
- Control Transformer
- Purge Flow Indicator
- Contacts for Common Alarm
- Fail-Safe Operation
- Over-temperature Safety Control
- Control Air Filter
- 150 PSIG MAWP
- Stainless Steel Diffuser Screens
- Separate Tower Fill/Drain Ports
- Cushioned Seat Check Valves
- Moisture Indicator
- Centrifugal Compressor Surge Protection
- ASME Vessels
- Pressure Equalization

Optional Equipment

- PowerLoc Automatic Energy Management System Includes:
 - Digital Dew Point Readout
 - High Humidity Alarm
 - Demand Regeneration Control
- All NEMA Classifications
- Pressure to 1000 PSIG
- Outdoor Tower Insulation
- Dew Points to -100°F (-73°C (TWP))
- Pre and After-Filter Sets
- Filter Mounting
- Filter Installation with ΔP Indicator and Electronic Drain
- Other Voltages
- Non-Yellow Metals
- Communication Options:
 - Modem (Standard Large Systems)
 - Ethernet
 - 3G Cell Modem

Note: Specifications and dimensions are subject to change without notice.

Capacity Correction Factors

		INLET AIR PRESSURE CORRECTION										
A	PSI	50	60	70	80	90	100	110	120	130	140	150
	BAR	3.5	4.1	4.9	5.5	6.2	6.9	7.6	8.3	9.0	9.7	10.3
	FACTOR	.56	.65	.74	.83	.91	1	1.09	1.18	1.27	1.37	1.43

		TEMPERATURE CORRECTION							
B	TEMP	90	95	100	105	110	115	120	
	$\frac{^{\circ}F}{^{\circ}C}$	32	35	38	41	43	46	49	
	FACTOR	1.35	1.16	1	.85	.74	.64	.56	

EXAMPLE CALCULATIONS

TWP500 Corrected for 120 PSI (8.3 Bar) +110°F (43°C)

$$\begin{aligned}
 \text{CORRECTED CAPACITY} &= (\text{RATED CAPACITY}) \times (\text{PSI Correction}) \times (\text{Temperature Correction}) \\
 &= 500 \text{ SCFM (13.9 Nm}^3\text{/min)} \times (1.18) \times (.74) \\
 &= 437 \text{ SCFM (12.1 Nm}^3\text{/min)}
 \end{aligned}$$



Patents issued: 6,099,620; 5,207,072; 5,099,655; 5,062,571; other patents pending. The equipment indicated in the catalog is meant for use in operating "compressed air driven" apparatuses. At no time should any Airtek equipment be used for breathing air situations unless all government regulations regarding breathing air are met.

Airtek®, Smart Cycle®, Cold Trap®, StarWatch® and Powerloc® are Registered Trademarks of Rayco Enterprises, Inc. DBA Airtek

© 2001 Rayco Enterprises, Inc. DBA Airtek, Lancaster, New York Printed in U.S.A. Brochure ID # DES 1-2003

4087 Walden Avenue
Lancaster, New York 14086
Ph. 716.685.4040 Fx.716.685.1010

Email: airtek@airtek.com

Member



www.airtek.com